

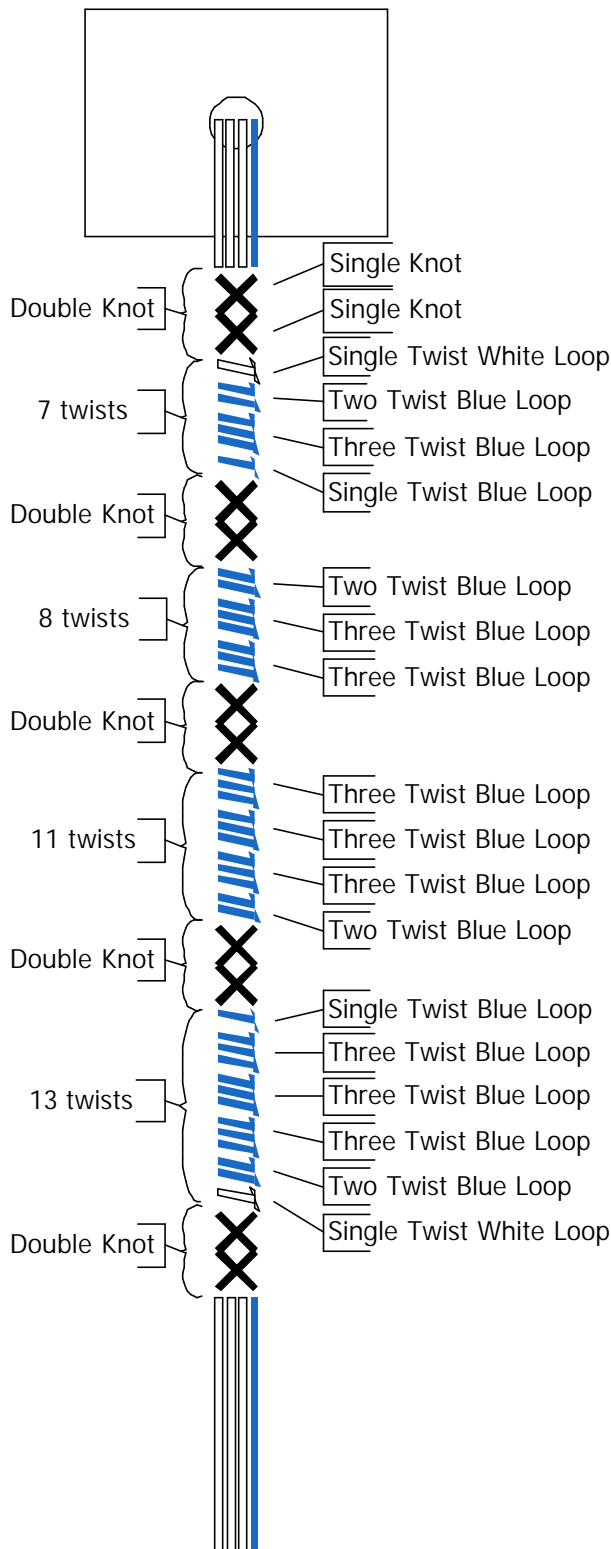

# Tekhelet Tying Diagram Series:

Radzyn - Chabad

by Mois Navon  
Ptil Tekhelet Organization



## Notes:

- 1) A "Single Knot" is made by taking the four strands from one side of the garment and the opposing four strands from the other side of the garment and tying a simple knot.
- 2) A single white twist loop is made by taking one white strand from the eight strands, wrapping it once around the remaining seven strands, and then tucking in the end in the wrap. This "wrapping" strand is designated "Shamash" and is used for the both the first and final white wrap (though it is not halachically imperative that the same Shamash be used).
- 3) A single blue twist loop is made the same as a white one, but just using a blue strand.
- 4) A two or three twist loop is made as follows: hold the seven "core" strands in the left hand (with the thumb extended out to the right), Take the blue shamash in the right hand and wrap it under and around the left thumb, then over the seven "core" strands, and then bring it up through the open "triangle" created by the blue shamash. Wrap the shamash around the seven strand "core" once more to make a two twist loop or two more times to make a three twist loop. Now pull all the strings tightly together (this will require some play). Note: it helps to pull tight from the bottom first.

For my **Pictorial Detailed Instruction Sheet** click one of the following links:

- [HTML page](#)
- [Low resolution PDF](#)
- [Hi resolution WORD](#)